

# AMC Series programmable intelligent meters

Installation and Operation Instruction V2.2

ACREL CO.,LTD

## Declaration

No part of this publication may be reproduced, stored in a retrieval System, or transmitted in any form by any means, electronic, mechanical photocopying, recording, or otherwise without prior permission of Acrel.

All rights reserved.

This company reserve power of revision of product specification described in this manual, without notice. Before ordering, please consult local agent for the new specification of product.

## Contents

1 Summary.....	1
2 Type Description.....	1
3 Technical parameter.....	2
4 Installing and wiring.....	2
4.2 Diagram of meter and its cut out.....	3
4.3 Installing.....	3
4.4 Terminals and wiring.....	3
4.5 Notice.....	6
5 Operating description.....	7
5.1 Key function description.....	7
5.2 Programming menu.....	7
5.3 Setting and use.....	9
5.4 View switching display and alarm status.....	17
6 Communication.....	18
6.1 Summary.....	18
6.2 Protocol.....	18
6.3 Method to create error check code (CRC).....	19
6.4 Communication parameter address meter (Word).....	20
6.5 Communication application.....	21
7 Common fault analysis.....	23

## 1. Summary

AMC series programmable intelligent meters, adopting AC sampling technology, can directly or indirectly measure electric voltage and current of single phase or three phase grid. It can be used for local display, and connecting industrial control device to form measuring control system.

This series of meters have RS-485 port, adopt Modbus-RTU protocol. Analog output, alarm output, switching input/output can be selected. Based on different request, by pressing the keys, parameters of ratio, alarm, communication etc. can be modified.

## 2. Type Description

Table 1

Type	Basic function	Shape	Optional function
AMC48-AI AMC48-AV	Current, voltage measurement; LED	48 Square	RS485 communication (/C ) Analog output (/M )
AMC48-AI3 AMC48-AV3			None
AMC48L-AI AMC48L-AV	Current, voltage measurement; LCD		1.RS485 communication (/C ) 2. Analog output (/M )
AMC48L-AI3 AMC48L-AV3			None
AMC72-AI AMC72-AV AMC72-AI3 AMC72-AV3	Current, voltage measurement; LED	72 Square	1.RS485 communication (/C ) 2. Analog output (/M ) 3. Alarm output (/J)
AMC72-DI AMC72-DV	DC voltage, current measurement; LED		4. Analog output + RS485 communication (/MC )
AMC72L-AI AMC72L-AV AMC72L-AI3 AMC72L-AV3	Current, voltage measurement; LCD		5. RS485 communication + switching output 2DI2DO (/KC ) 6. Alarm output + analog output + RS485 communication (/JMC )
AMC72L-DI AMC72L-DV	DC voltage, current measurement; LCD		
AMC96-AI AMC96-AV AMC96-AI3 AMC96-AV3	Current, voltage measurement; LED	96 Square	1.RS485 communication (/C ) 2. Analog output (/M or /3M ) 3. Alarm output (/J) 4. Analog output + RS485 communication (/MC or /M3C )
AMC96L-AI AMC96L-AV AMC96L-AI3 AMC96L-AV3	Current, voltage measurement; LCD		5. RS485 communication + switching 4DI2DO (/KC ) 6. Alarm output + analog output + RS485 communication (/JMC )
<b>Note: 1. AI/AV means single-phase current/voltage, AI3/AV3 means three-phase current/voltage; 2. /J means 1 channel relay output (multiplexing with second channel switching output)</b>			

### 3 Technical parameter

Table 2

Technical parameter		Value
Input	Rated value	AC voltage:Single phaseAC 100V,400V Three phaseAC 100V,400V,660V(UL-L,Only 72/ 96) AC current:AC1A,5A; DC voltage:1000V,300V,75mV,10V; DC current: 0-20mA,4-20mA,5A;
	Overload	Voltage: 1.2 times rated value(continuous); 2 times rated value /1 second Current:1.2 times rated value(continuous); 10 times rated value /1 second
	Frequency	45Hz~65Hz
	Power consumption	Power consumption of each voltage,current input circuit is less than 0.5VA
Accuracy		0.5 class
Function	Display	LED or LCD
	Communication	RS485,Modbus-RTU protocol;(1 start bit,8 data bit,1 stop bit,no parity) Baud Rate 2400/4800/9600/19200 bps etc.
	Alarm	1 channel passive relay,contact capacity 3A/30VDC,3A/250VAC, Used for high,low,unbalance alarm etc.
	Analog	DC4~20mA,( load <500Ω) (note:Shielded wire is specially selected for the above signal input and output)
	switching	Input
Output		2 channel switching output,NO relay contact,capacity: 3A/30VDC,3A/250VAC
Auxiliary supply	Voltage range	AC/DC 85-265V
	Power consumption	<5VA
Insulation resistance		≥ 100MΩ
Power frequency withstand voltage		Between power supply set of terminals and signal input,output set of terminals 2kV/1min (RMS) Between the shell and all set of terminals(except the set of terminals reference voltage less than 40V) AC 4kV
Environment	Temperature	Operation: -10°C~+55°CStorage: -25°C ~+70°C
	Humidity	≤95%RH,no condensation,without corrosive gas
	Altitude	≤ 2500m

### 4 Installing and wiring

#### 4.1 Outline and mounting cut out size (Unit: mm)

Table 3

Shape	Panel		Housing			Cut out	
	Unit:mm	Width	Height	Width	Height	Depth	Width
48 Square	49	49	44	44	93	45	45
72 Square	75	75	66.5	66.5	94.3	67	67
96 Square	96	96	90	90	77.8	92	92

## 4.2 Diagram of meter and its cut out

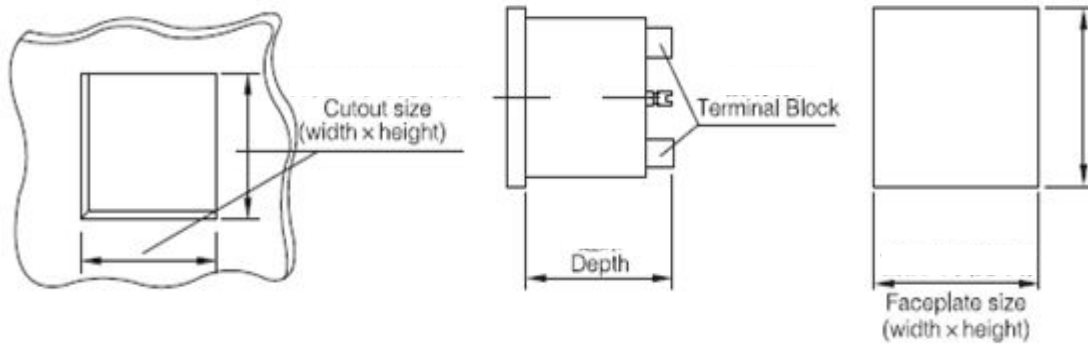

## 4.3 Installing

- 1) Make holes on distribution cabinets;
- 2) Take out the meter and the buckle;
- 3) The meter is loaded into the mounting hole from the front, as shown in Figure 2;
- 4) Insert the buckle and fix the meter, as shown in Figure 3.



图 2

图 3

## 4.4 Terminals and wiring

According to different design requirements, it is recommended to add a fuse (BS88 1A gG) to the power supply and voltage input terminals to meet the safety requirements of relevant electrical codes.

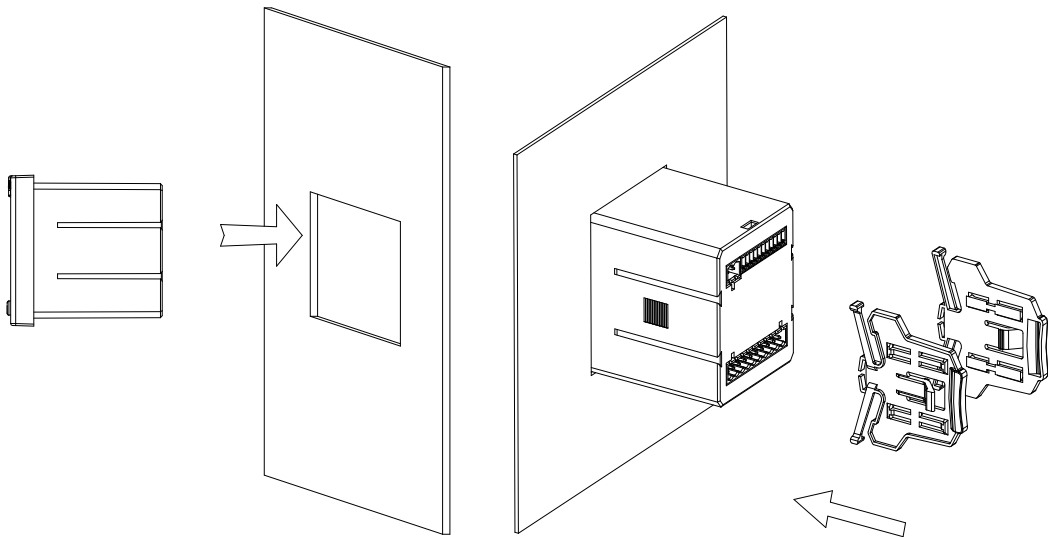
### 4.4.1 Terminals and wiring

Analog wiring:

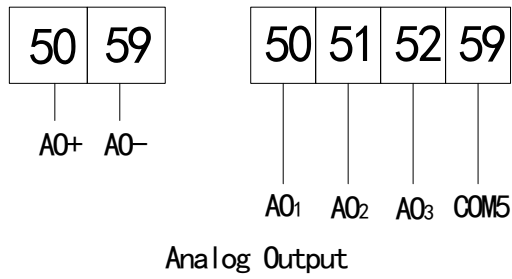

Switching input wiring:

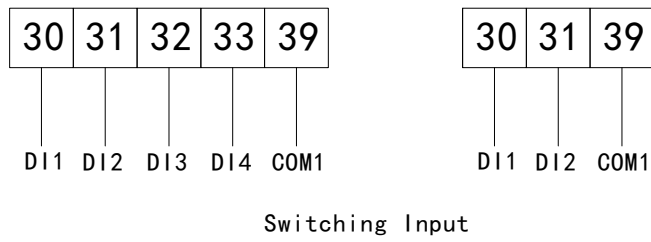

Switching output or alarm wiring:

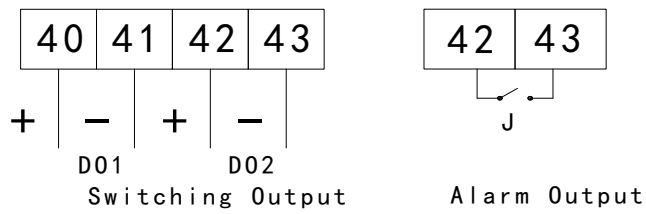

RS-485 wiring:

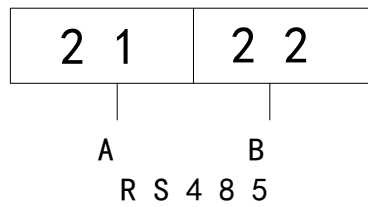

Power wiring:

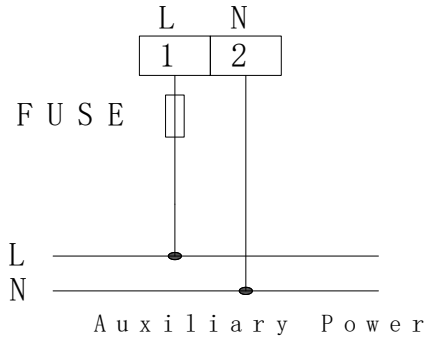

Voltage or current wiring:

single phase:

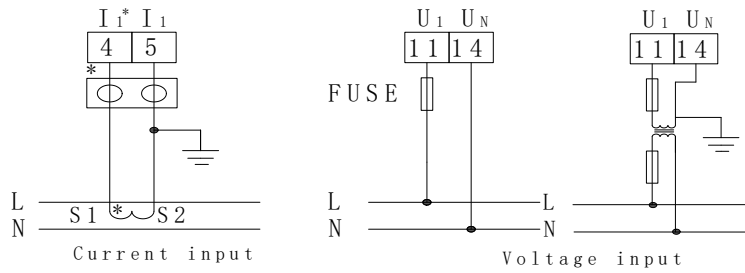

Three phase:

Three phase voltage:

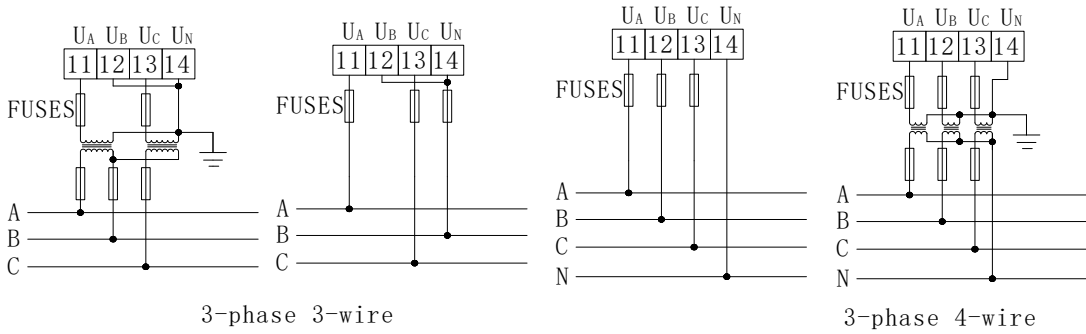

AMC72/96 Voltage

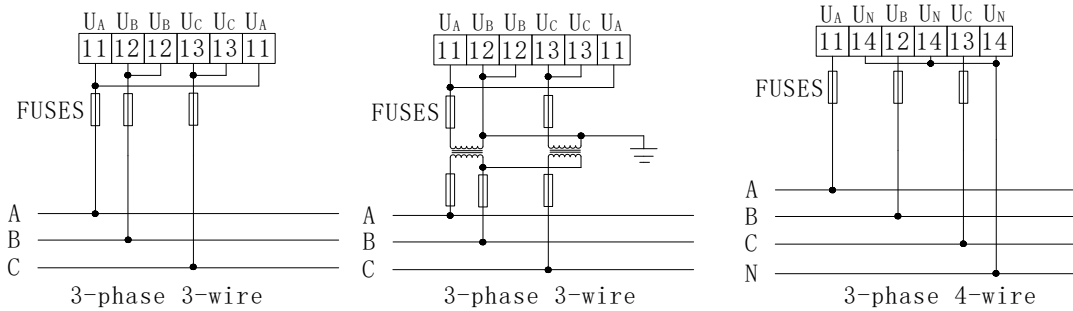

AMC48 Voltage



Three phase current:

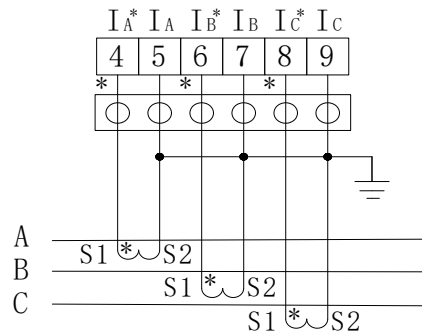

DC series:

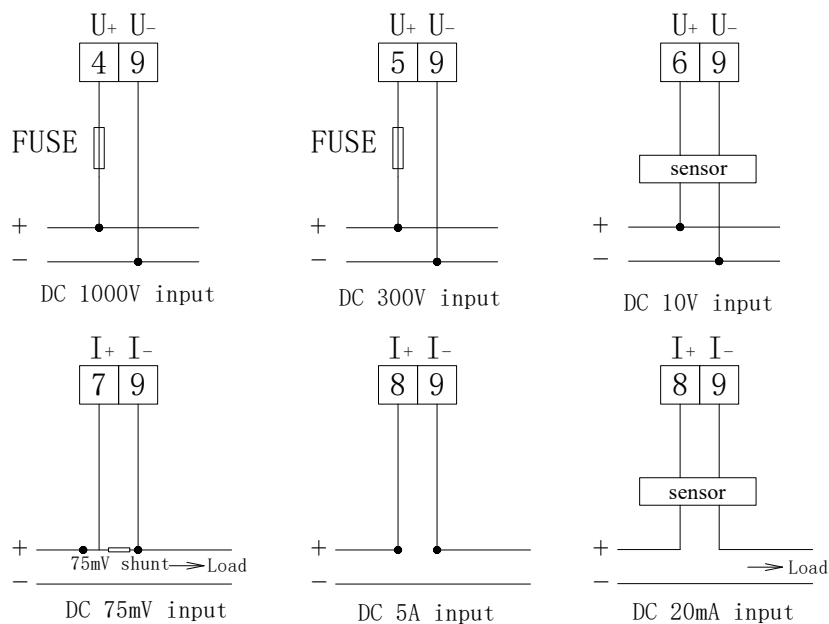

**Note:1. The symbol "\*" indicates current input terminal, this wiring is for reference only, the specific wiring diagram on the meter prevail;**

**2. Alarm output relay duplex with the second switching output (DO2).**

#### 4.5 Notice

##### 4.5.1 Voltage Input

The input voltage must not be higher than the rated input voltage of the product, otherwise PT should be considered

A 1A fuse must be installed on the voltage input.

##### 4.5.2 Current Input

Current input shall use external CT;

If the used CT connected with other meters, the connection should be used in series;

It is recommended to use wiring board, do not connected with CT directly, in order to remove conveniently;

Before removing product's current input connection, be sure to disconnect the CT primary circuit or short the secondary circuit.

##### 4.5.3 Additional function wiring

COM of analog output and switching input represent their own common end, it is not earthing actually.

Two-core shield cable is recommended for communication connection. Its wire diameter is not less than 0.5mm<sup>2</sup>, connecting A B respectively, shielded layer single point to connect the earth or dangling. When wiring, the communication line shall be far away from strong current cable and other strong electric field environment.

For connection mode in communication section are shown as following:

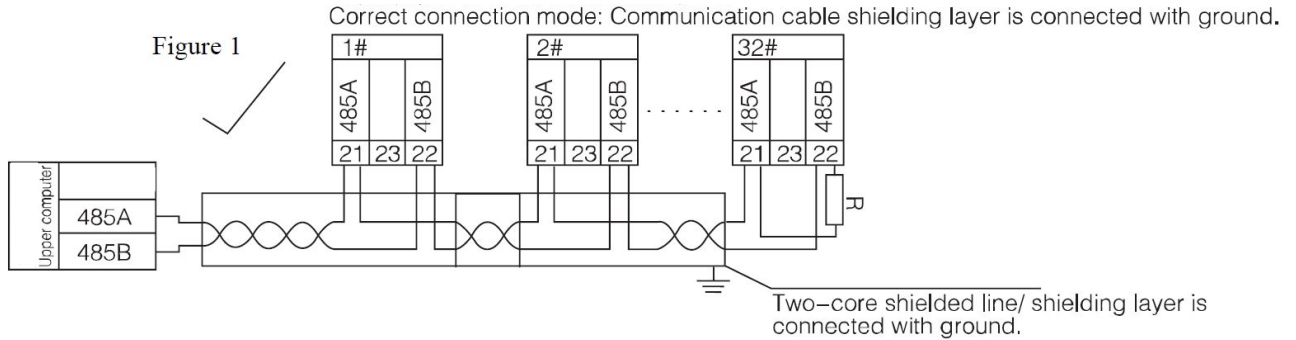

Recommendation of adding matched resistance between A, B of the last meter, the rated resistance range is 120Ω~10kΩ.

## 5 Operating description

### 5.1 Key function description

Table 4 Key function description

Key symbol	Function
SET ( SET )	Return to previous menu or Function switching
Left ( ◀ )	Same level menu shifting left or reducing data
Right ( ▶ )	Same level menu shifting right or increasing data.
Enter ( ↵ )	Enter Next level menu or Confirm.
Left+ ente◀ + ↵ )	In programming mode, this key combination is used for the reduction of hundreds of digits.
Right + ente▶ + ↵ )	In programming mode, this key combination is used to increase the hundred digits.

**Note:** When using the combination key, you can firstly press the left or right key and then press the Enter key.

### 5.2 Programming menu

#### 5.2.1 Menu symbol and its meaning

table 5

First menu	Second menu	Third menu	Description
SYS	Code	0~9999	Password setting (initial password 0001)
	bLcd	0~255	LCD backlight control, when set to 0, the backlight is always on, when set to 0-255, the backlight is off after 0-255 seconds
	AL.-F	ON/OFF	Whether the screen flashes when alarming

In	Line	3P3L,3P4L	Electrical network (3-phase 3-wire,3-phase 4-wire) Note: just for 3 phase voltage
	In. I (In.U)	1A,5A (100V,400V,660V)	Current rated value (Voltage rated value)
	In.Ct (In.Pt)	0~9999	Current ratio (Voltage ratio)
	H	-9999~9999	Full scale display
	L	-9999~9999	Zero display
	U.P. (R.P)	0~3	Decimal point of current (voltage) display
	2	-9999~9999	Shielding value of zero display
bus	Addr	1~247	Communication address
	brud	1.2,2.4,4.8, 9.6,19.2,38.4	Baud rate (Example 9.6 means 9600bps)
	node	None/2bit/odd/even	Communication mode (No parity check,2-bit stop bit,odd parity check,even parity check)
tr.1-tr.3	SEL	1,2,3	Analog output selection
	TYPE	4~20mA or 0~ 20mA	Output type
	Ro.H	0~9999	High analog value setting
	Ro.Lo	0~9999	Low analog value setting
do.1-do.2	SEL	0.do/1.AL	Alarm selection
	dLY	0~20	Alarm delay or remote control delay (s)
	brnd	0~9999	No action band setting

	ALH <sub>1</sub>	0~9999	High alarm value setting
	ALLo	0~9999	Low alarm value setting
	AL-b	0~100	Unbalance alarm setting (%)
	In.=0	Lo.on/Lo.of	Whether alarm is allowed when the signal is 0
VER			Version

### 5.3 Setting and use

The programming example introduces some of the options in the programming menu, such as current ratio, analog output setting, and switching output setting etc.

**Note:** After the setting or selection is completed, press the Enter key to confirm. After confirming the completion, press the SET key until the SAVE/YES page appears. At this time, you must press the Enter key to confirm, otherwise the setting is invalid.

#### 5.3.1 How to enter the programming menu

Single phase:

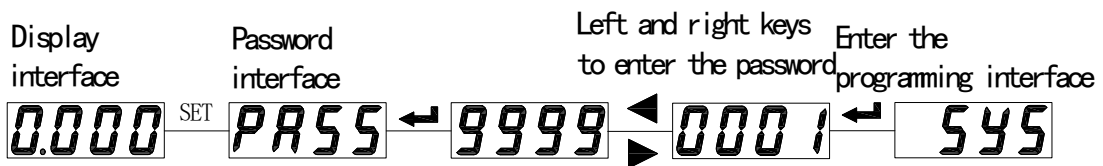

Three phase:

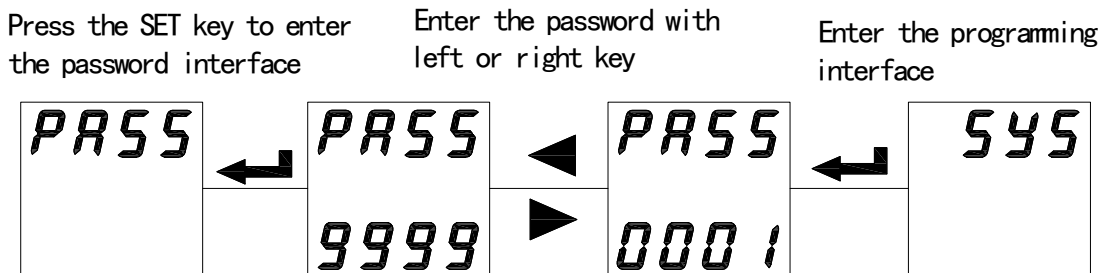

#### 5.3.2 How to save the modified parameters

Single phase:

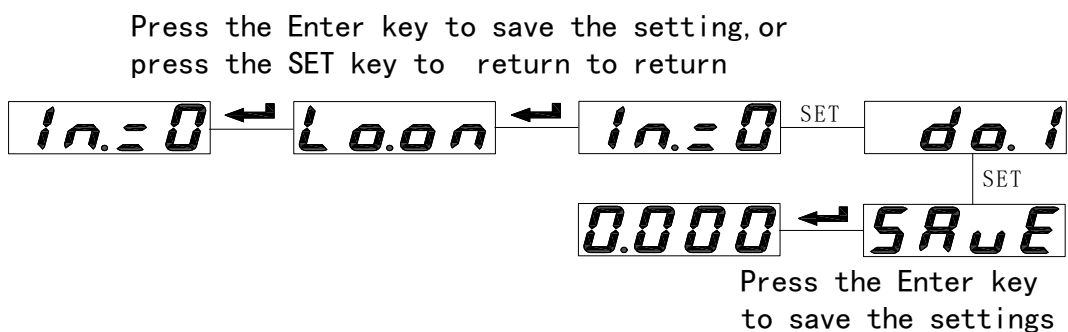

Three phase:

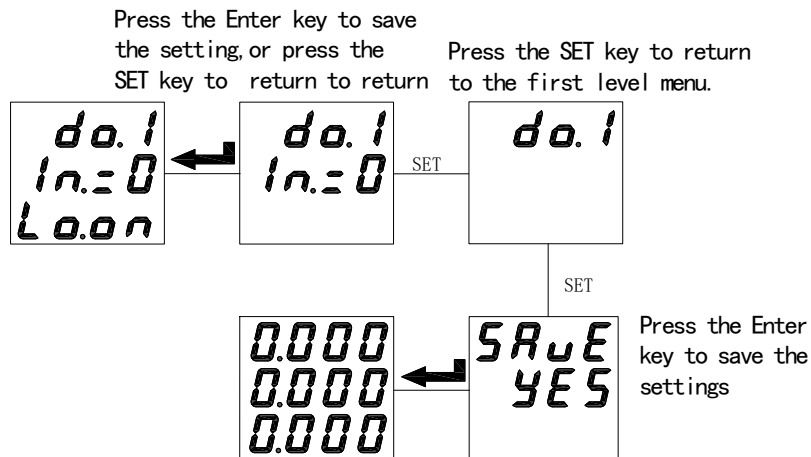

**Note:** You do not need to save the parameter after modifying one. You can save all the parameters after modifying them as described above.

### 5.3.3 How to modify the password, backlight time etc.

Single phase:

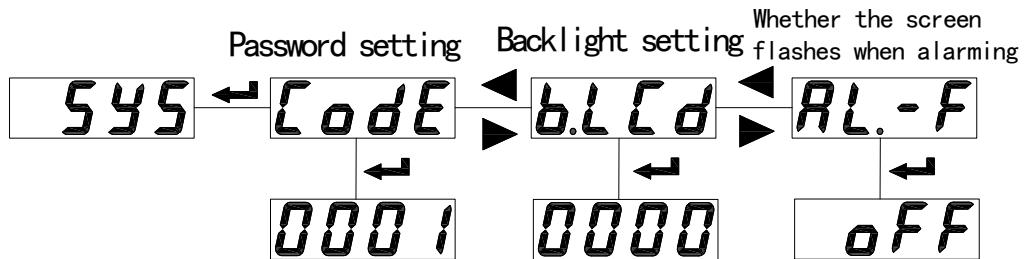

Three phase:

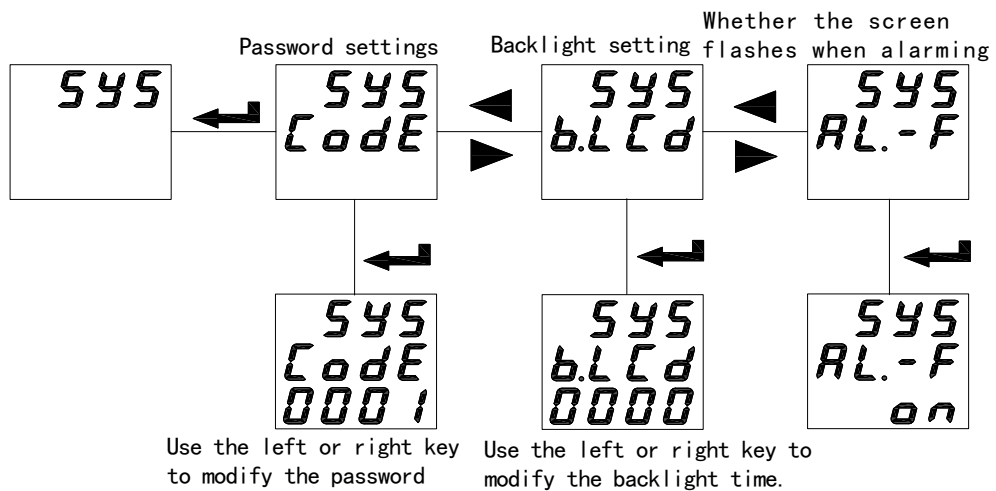

Enter the programming menu, press left or right key to select the LCD page, press Enter key to enter revising condition, left or right key to modify the time to 000 ~ 255s. To LED display meter, this item is invalid.

000: the LCD backlight is always on;

250: the LCD backlight has no backlight after 250 seconds, and the backlight is turned off to extend the life of the backlight.

### 5.3.4 How to modify the current rated value and current ratio

Single phase:

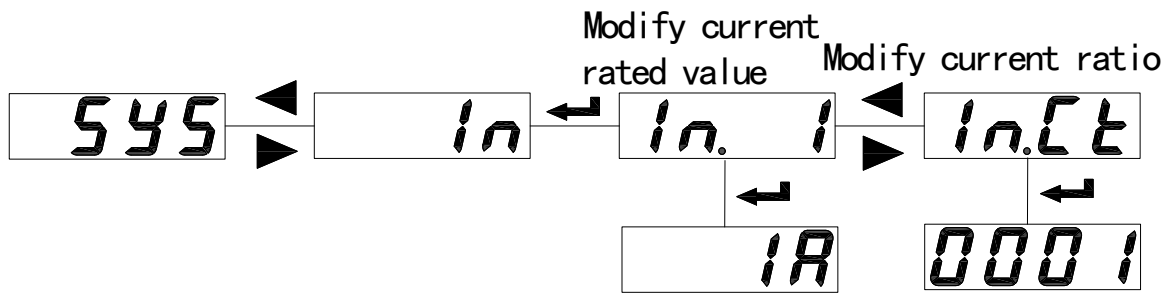

Three phase:

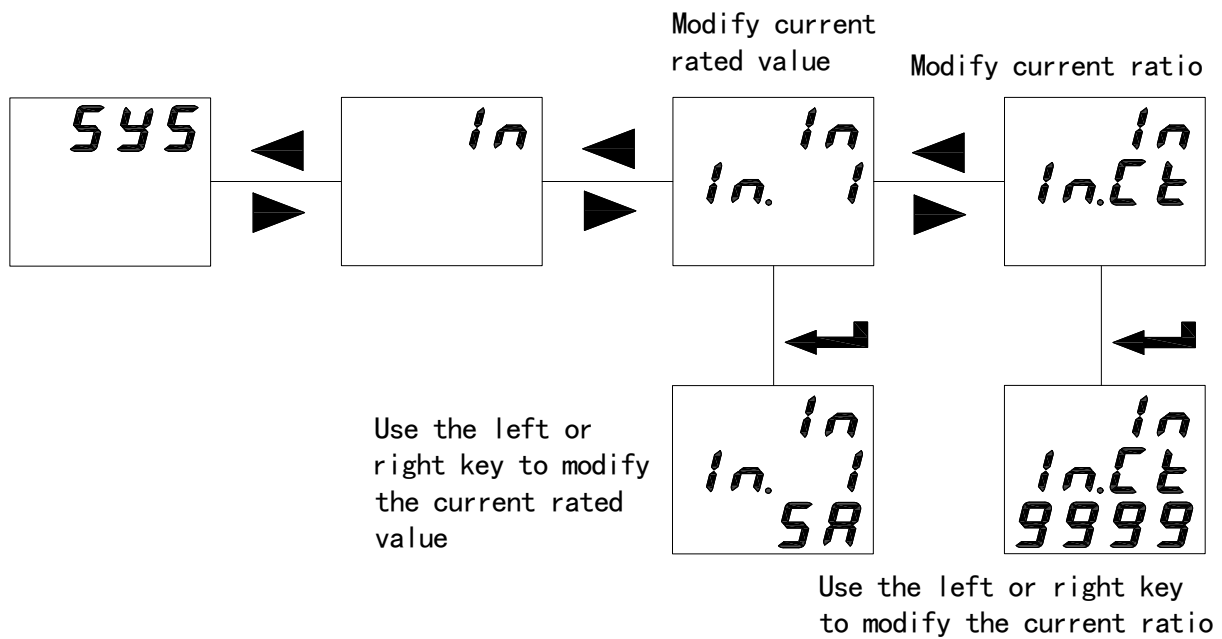

**Note:** IN.I is the current rated value ,IN.U is the input voltage rated value; IN.CT is the current ratio, and IN.PT is the voltage ratio.

### 5.3.5 How to modify the DC display value

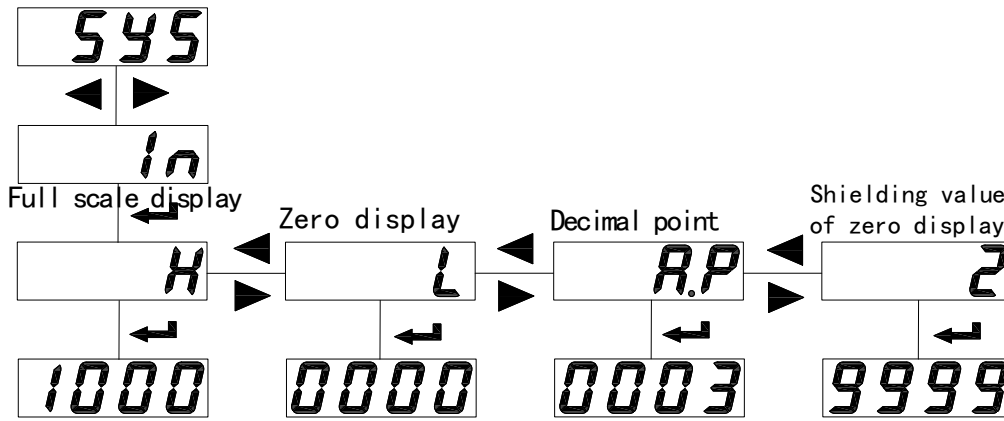

The DC voltage meter is the same, only one difference: U.P replaces A.P;

When the zero shielding value is set to positive, it means that if  $|\text{display value}| \leq \text{set value}$ , the display value is 0 (Fig. 6); When the set value is negative, then the display value is set value when the display value  $\leq \text{set value}$  (Fig. 7).



图 6



图 7

### DC meter setting

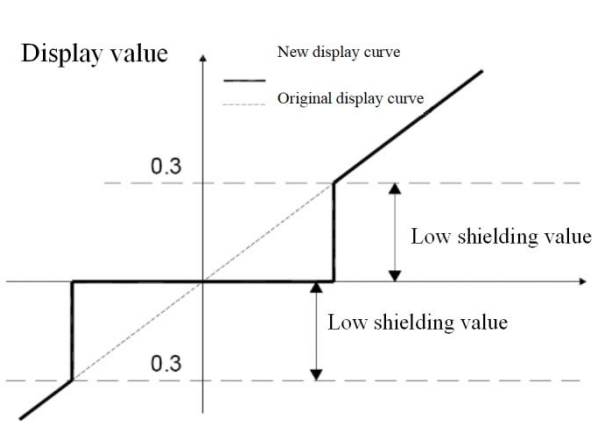
**H:** DC high point display value; **L:** DC zero point display value, **A.P (U.P):** Display decimal point

**When the low point of the input is 0:**

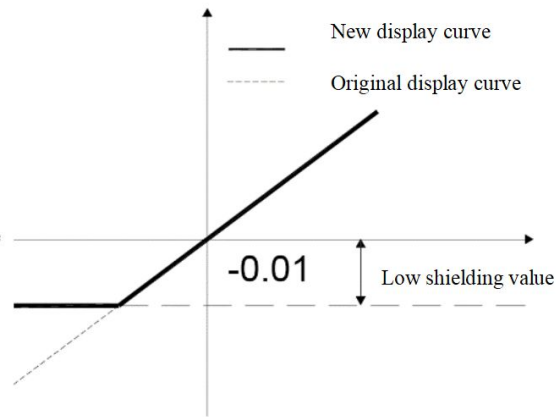
For example: The input signal is 0-75mV, and the relative display needs to be 0-1000A, then the setting will be: H: 1000, L: 0, A.P: 0. So when the input is 37.5mV, the display will be 500  $((1000-0) \cdot (37.5/(75-0)))$ .

**When the low point of the input is not 0:**

For example: The input signal is 4-20mA, and the display needs to be 0-60.00Hz, then the chart of the relationship will be as follows:

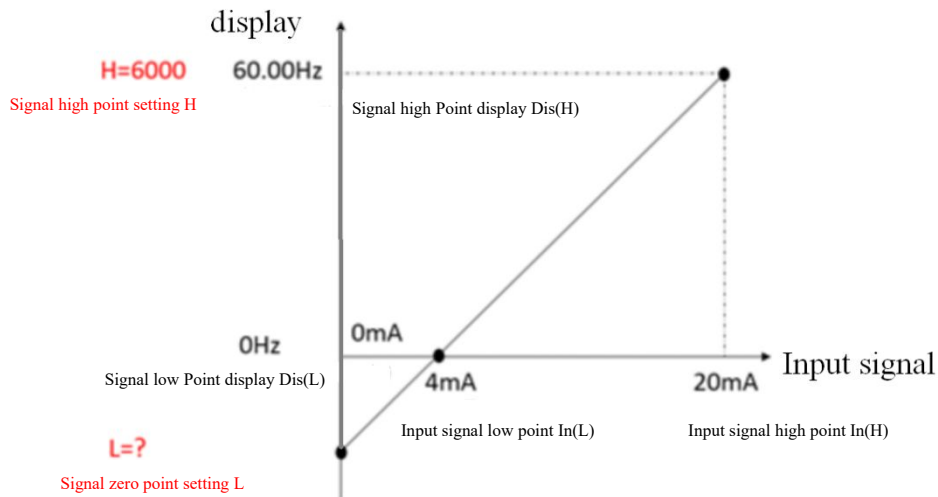

Setting: H: 6000,fiWe can get L according to the chart:  $(In(H)-In(L))/In(L) = (Dis(H)-Dis(L))/(Dis(L)-L)$ .  
 So  $L = 0 - (6000-0) * 4 / (20 - 4) = -1500$ .

A.P:2; so when the input is 4 mA,the display will be  $(6000-0) * (4/20) + (-1500) = 0Hz$

### 5.3.6 How to modify the communication address,communication baud rate and communication mode

Single phase:

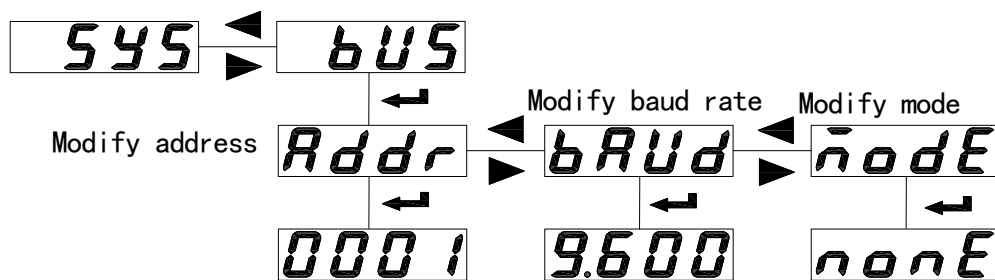

Three phase:

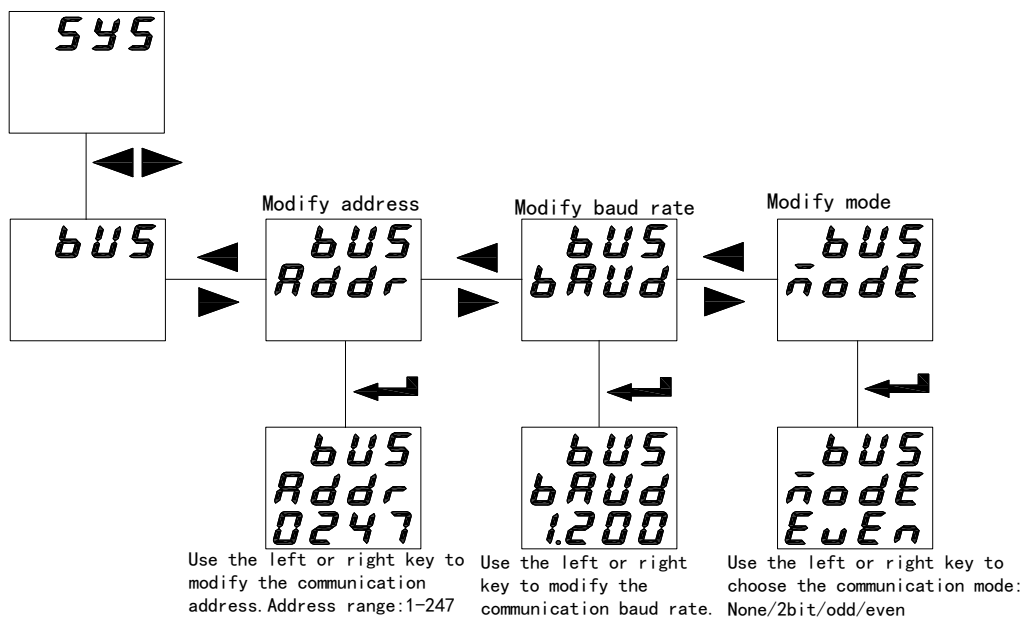

### 5. 3. 7 How to modify the analog output parameter,the output range and the high and low values



Table 6

<b>tr.1</b>	First analog output						
<b>SEL</b>	Analog output selection <table border="1"> <tr> <td>0001</td> <td>0002</td> <td>0003</td> </tr> <tr> <td>U1/I1</td> <td>U2/I2</td> <td>U3/I3</td> </tr> </table>	0001	0002	0003	U1/I1	U2/I2	U3/I3
0001	0002	0003					
U1/I1	U2/I2	U3/I3					
<b>TYPE</b>	4~20mA or 0~20mA						
<b>Ro.Hi</b>	When the analog output is 20mA, the corresponding electrical parameter is taken as the highest four-digit integer (the decimal point is ignored) and the last bit is zero.						
<b>Ro.Lo</b>	Same as Ao.Hi						

Single phase:

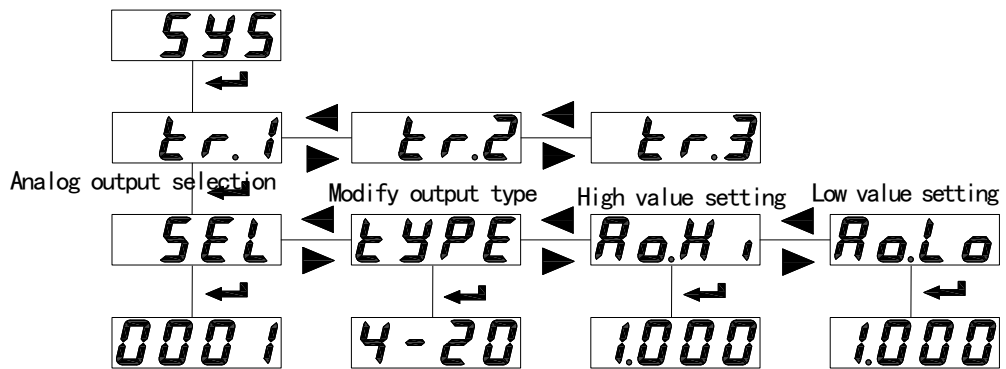

Three phase:

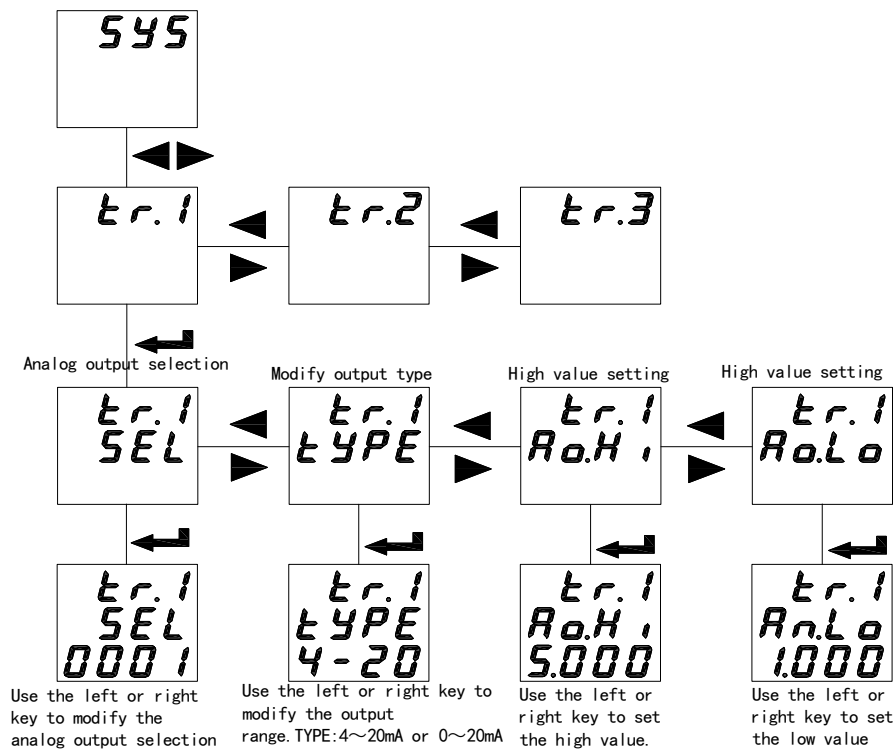

5.3.8 How to modify the alarm item, set the alarm delay, set the high and low alarm value and the unbalance alarm setting (1 way alarm is the same as 2 way alarm)

Table 7

<b>do.1</b>	First switching output				
<b>SEL</b>	Alarm setting <table border="1"> <tr> <td>0.do</td> <td>1.AL</td> </tr> <tr> <td>remote control</td> <td>alarm</td> </tr> </table>	0.do	1.AL	remote control	alarm
0.do	1.AL				
remote control	alarm				
<b>dLY</b>	When the SEL is 00 (remote control), DLY indicates the duration after the switching amount is activated. When the alarm item SEL is not 00 (alarm), DLY indicates the delay time before the switching action.				
<b>bRnd</b>	No action band setting				
<b>ALH<sub>1</sub></b>	High alarm value setting (do not set the maximum 9999)				
<b>ALLo</b>	Low alarm value setting (do not set minimum 0)				
<b>In.=0</b>	Whether low alarm is allowed when the signal is 0, Lo.on is enabled, Lo.of is forbidden				

Single phase:

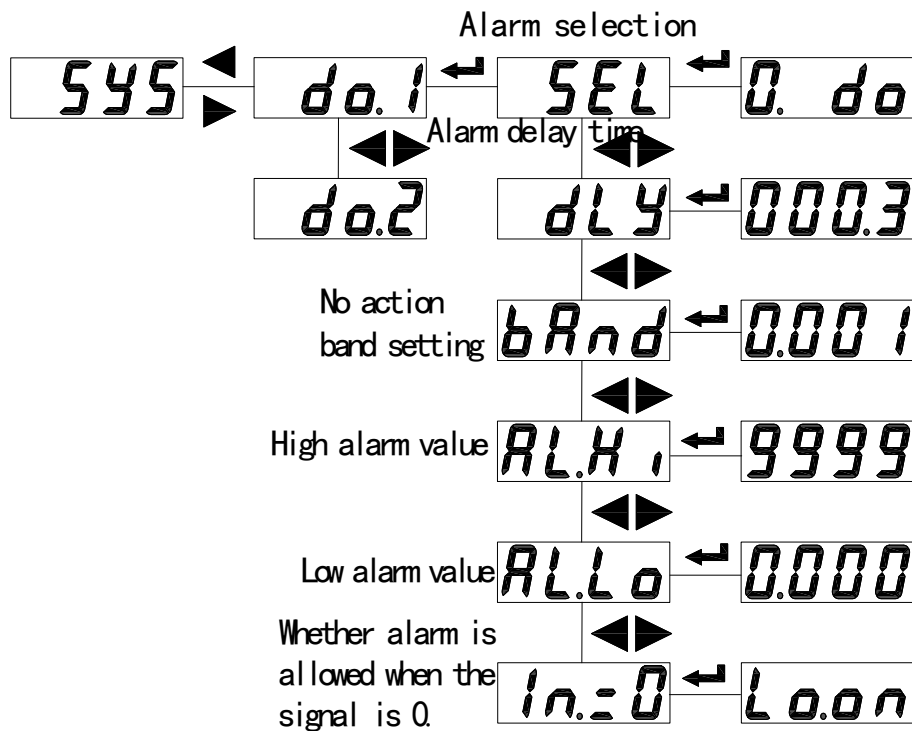

Three phase

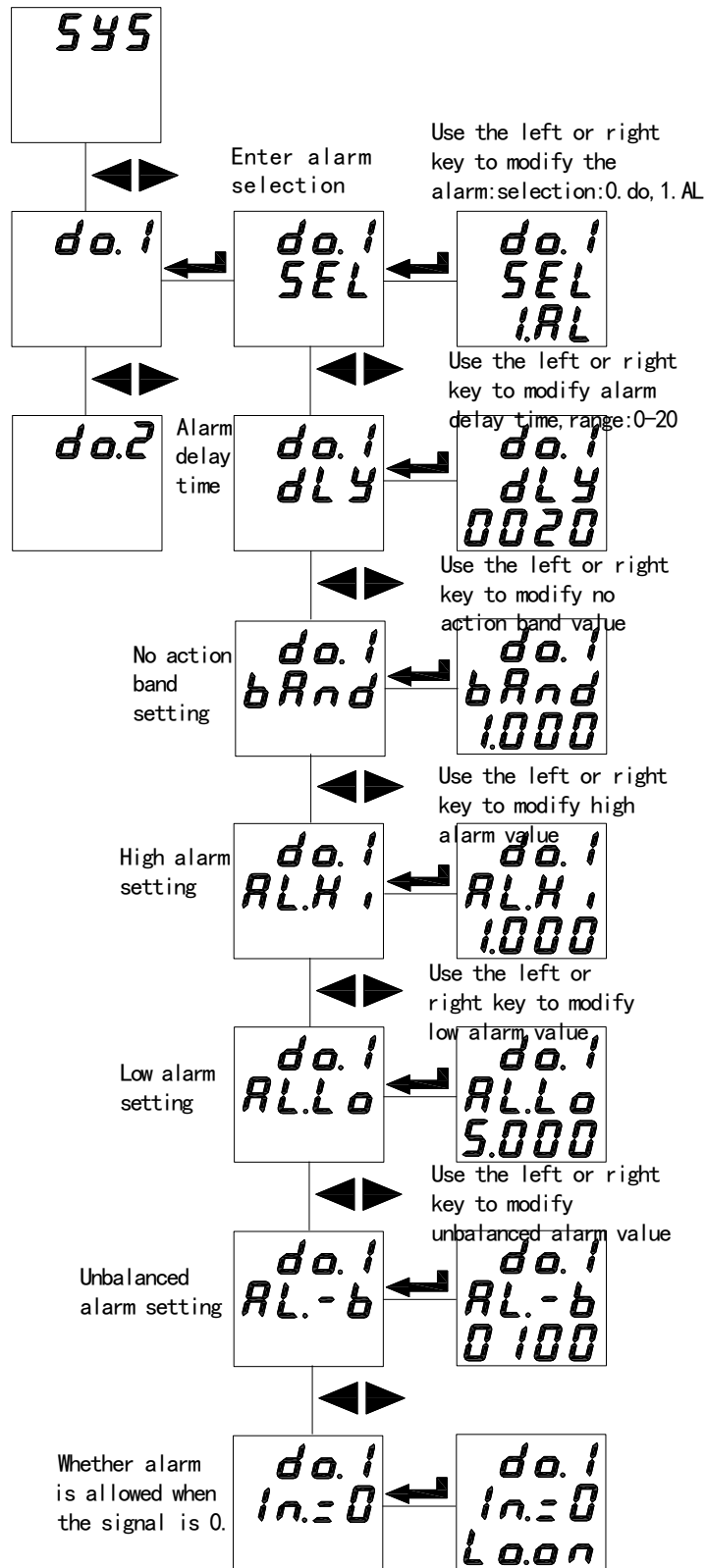

**Note: 1. No action band setting,high alarm value setting and low alarm value setting correspond to the display value of the meter,and the value contains a decimal point. Example: Input 100A/5A,100% current high alarm,95% return; 20% current low alarm,25% return,"AL.Hi"taken as 100.0,"AL.Lo"taken as 020.0,"bAnd"taken as 005.0;**

**2.Unbalancecalculation**

(maximum value–minimum value)/rated value (average value is less than rated value)

(maximum value–minimum value)/average value (average value is greater than or equal to the rated value)

### 5.4 View switching display and alarm status

#### 5.4.1 View switching

View the switching status of AMC96 (L) three-phase current meter (same three-phase voltage meter):

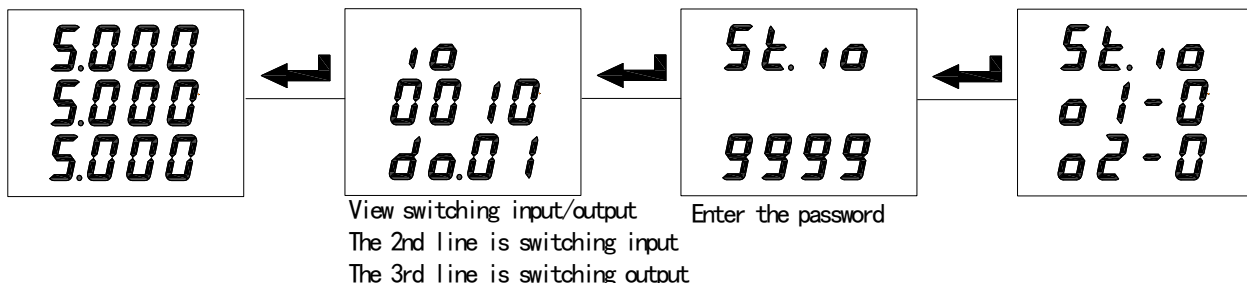

View the switching status of AMC72 (L) three-phase current meter (same three-phase voltage meter):

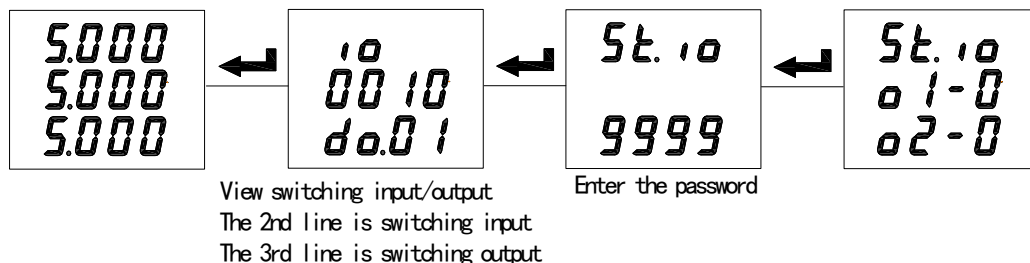

View switching input/output  
The 2nd line is switching input  
The 3rd line is switching output

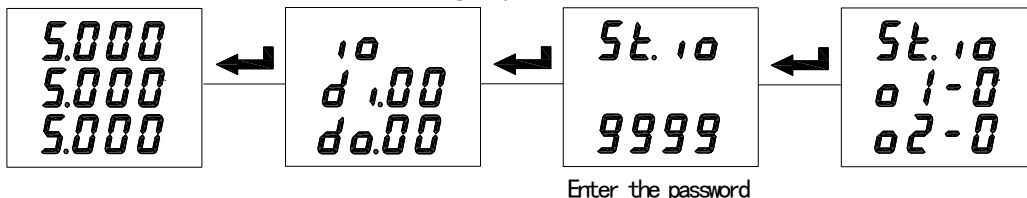

View the switching status of AMC72/96(L) single-phase current meter(same single-phase voltage meter):

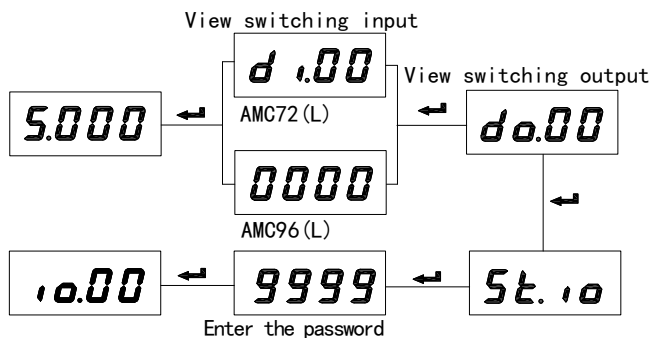

The liquid crystal (LCD) display meter has a switching input/output indication under normal measuring condition,without pressing the shortcut key to look over.

When look over switching condition page,press down ENTER,Enter local switching output (relay)control page (St. io),press left/right key to enter protective password (Default Value; 0000),press ENTER to confirm enter;the data flashes indicate revisability,press left key to select revising item,press right key to do revising,press ENTER to confirm revising; If Control two channel relay is needed,firstly,finishing all the revising,then press ENTER to confirm.

#### 5.4.2 View alarm status

Alarm status (for normal measurement,press and hold the right shift key to view the alarm information)

AMC72/96 series single-phase meter alarm status:

			No alarm when the value is 0
normal	I too high	I too low	

AMC72/96 series three-phase meter alarm status:

				No alarm when three-phase data is 0
normal	U1(I1) is too high	U3(I3) is too low	Unbalanced or none-full phase	

## 6 Communication

### 6.1 Summary

AMC Series meter adopt Modbus-RTU protocol: "9600,8,n,1",in it 9600 is default baud rate,based on request,it can be revised as 2400,4800 ,19200 etc.,8 indicate have 8 data bit; n indicate no parity bit; 1 indicate have one stop bit.

Error detecting: CRC16 (cyclic redundancy check)

### 6.2 Protocol

When Data frame reach terminal device,it enter addressed device by a simple "port",this device remove Data frame "envelope"(data head),read data,if there is no error,executing task requested by data,then,add the new produced data in the obtained "envelope",return the data frame to the transmitter. Returned responding data include following content: slave terminal address (Address),executed command (Function),requested data produced by executing command (Data) and one CRC check code (Check). If any error occur,no successful responding or returning one error indication frame.

#### 6.2.1 Data frame format

Address	Function	Data	Check
8-Bits	8-Bits	N×8-Bits	16-Bits

#### 6.2.2 Address domain

Address domain: address domain is located at beginning of frame, composed of one byte (8 bit binary system domain), decimal system is 0-255, in our system, just 1-247 is used, other address is Reserved, these bits indicate terminal device address specified by users, this device will receive the connecting host computer data. Every terminal device has its only one address, only the addressing terminal is responding enquiry including this address. When terminal is Transmitting one responding, the responding slave address data tell host computer that which terminal is communicating with it.

### 6.2.3 Function domain

Function domain: function domain tell the addressed terminal to execute what function, Below table list: function domain used in this Series meters, and their meaning and function.

Code(hex)	Meaning	Operation
03H	Read holding register	Obtain current binary system value of one or multiple holding register
10H	Present multiple register	Set actual binary system value into a series of continuous holding register

### 6.2.4 Data fields

Data field: data field is including the data needed by terminal for executing specific function, or the collected data when terminal is responding enquiry. Content of these data may be value, reference address or setting value.

For example: The function domain tell terminal to Read one register, the data field need to specify the starting register and Read how many data, the built-in address and data have different content depending on type and slave computer.

### 6.2.5 Error check domain

This domain adopt CRC16 cyclic redundancy check, for host computer and terminal, the error in checking and transmitting is allowable. Due to electric noise and other interfere, when one group of data is transmitting from one device to another device, on the transmitting line, some change may be produced. The error check can enable the host computer or slave computer not responding those changed data, so, safety, reliability and efficiency of system are upgraded.

## 6.3 Method to create error check code (CRC)

Error check (CRC) domain occupy 2 byte, including one 16 bit binary system value. CRC value is calculated by transmission device, then attached to the data frame, the receiving device, while receiving, it calculates the CRC value again, then comparing it with the receiving CRC domain value, if these two values is not equal, it shows a error occurs.

When operating, firstly, preset one 16-bit register as All-1, then continuously operating each byte 8 bit of Data frame and current value of this register, only every 8 data bit of each byte to participate in forming CRC the start bit and stop bit and usable parity bit have no affect on the CRC. When forming CRC, every 8 data bit of each byte and content of register carry out exclusive or operation, then shift the result to the low bit the high bit is filled with 0, shift out the least significant bit (LSB) is shifted out and tested, if it is 1, this register and one preset fixed value (0A001H) carry out one exclusive or operation, if the least significant bit is 0, no treating is needed.

Flow for forming one CRC:

1. Preset one 16 bit register as OFFFH (All-1), called as CRC register.
2. 8 bit of data frame first byte and low byte of CRC register carry out exclusive or operation, then save its result back to CRC register.
3. Right shift CRC register for one bit, the most significant bit is filled with 0, the least significant bit is shifted out and tested.
4. If the least significant bit is 0, Repeat the third step (next shift); If the least significant bit is 1, CRC register and

preset fixed value specified (0A001H) carry out exclusive or operation.

5.Repeat the third step and the fourth step until shift for 8 times,the complete 8 bit is done.

6.Repeat the second step to the fifth step to treat next 8 bit until all the byte is treated.

7.The CRC register final value is CRC value.

Besides,there is another CRC calculation method by preset table,its main feature is fast calculating speed,but large saving space is needed,please refer to related data

## 6.4 Communication parameter address meter (Word)

### 6.4.1 Communication parameter address meter (word)

Table 8

Address	Content		Brief Explanation	Brief Explanation
	Single phase	Three phase		
0000H	Ua effective value	Ua effective value		Read/Write:R-read;W-write  The 002aH is partial writable,the rest is read-only.  Explanation: ①"—"indicate Reserved word or Reserved bit. ②voltage,current etc. data numerical value Computing Method: Reading = Effective value ×10E( Exponential-3)
0001H	Ua exponent bit	Ua exponential		
0002H	Ia effective value	Ub effective value		
0003H	Ia exponent bit	Ub exponential		
0004H		Uc effective value		
0005H		Uc exponential		
0006H		Ia effective value		
0007H		Ia exponential		
0008H		Ib effective value		
0009H		Ib exponential		
000aH		Ic effective value		
000bH		Ic exponential		
....	— Reserved word			
0010H	PT		Voltage ratio	
0011H	CT		Current ratio	
0012H	Alarm and I/O			
...	— Reserved word			
002aH		Alarm and I/O		
002bH		PT	Voltage ratio	
002cH		CT	Current ratio	
...	— Reserved word			
0060H	UA voltage		UL-N when three-phase three-wire	Type of data: float Unit:V
0061H				
0062H	UB voltage		UL-L when three-phase three-wire	
0063H				
0064H	UC voltage		Single phase voltage meter:only UA	
0065H				
0066H	IA current		Three phase meter Three phase current	
0067H				

0068H	IB current	Single phase current meter :only IA
0069H		
006AH	IC current	
006BH		

Description:

Voltage and current calculating method: (example see 6.5.1 Reading data)

Reading = virtual value  $\times 10^E$  (exponent bit-3)

Alarm switching input / output status Character:

15	...	10	9	8	7	6	5	4	3	2	1	0
—			AL.L	AL.H	DI1	DI2	—		—		DO1	DO2
(R) H,L alarm indication				(R) 1 closing,0 opening				(R/W) 1 closing,0 opening				

15	...	13	12	11	10	9	8	7	...	0
—		H.L		A.-H	A.-L	U.-H	U.-L	Switching input/output status		
		Low power factor alarm		High,Low alarm of current		High,Low alarm of voltage		Same as above		

### 6.5 Communication application

Actual example, the whole way adopt format of below table (data as Hex)

Addr	Fun	Data start		Data #of		CRC16	
		reg Hi	reg Lo	reg Hi	reg Lo	Lo	Hi
01H	03H	00H	00H	00H	06H	C5 H	C8H
Address	Function code	Data start address		Data read number		CRC code	

#### 6.5.1 Read data

Example 1: Read Three phase voltage meter data

Inquiry Data frame	01 03 00 00 00 06 c5 c8
Return Data frame	01 03 0c 08 ab 00 02 08 ac 00 02 08 ac 00 02 1b 05

Explanation:

01: Slave address

03: Function code

0c: Hex, Decimal as 12, indicate: 12 byte data rearwards

1b 05: cyclic redundancy check code

Data processing method see: 6.4 communication parameter address meter

Processing as follows: 08 ab(hex)=2219(decimal)

08ac(hex)=2220(decimal)

0002(hex)=2(decimal)

Calculation:  $2219 \times 10^{2-3} = 221.9$ ;  $2220 \times 10^{2-3} = 222.0$

Unit: Volt (V)



Meter display:

U1	221.9
U2	222.0
U3	222.0

Reading voltage meter data is similar with that of reading current meter, but starting address is 06H, Query frame: 01 03 00 06 00 06 25 c9

Reading inquiry frames of other information is same as this format, each information address see: 6.4 communication parameter address meter.

#### Example2: Read single-phase current data

Inquiry Data frame	01 03 00 02 00 02 65 cb
Return Data frame	01 03 04 03 b2 00 00 5a 50

Description:

01: Slave address

03: Function code

04: Hex, decimal system is 4, means there are 4 byte data

5a 50: Cyclic redundancy check code

Data processing method see: 6.4 communication parameter address table

Data processing: 03 b2 (Hex) = 946 (decimal system)

00 00 (Hex) = 0 (decimal system)

Calculation:  $946 \times 10^{-3} = 0.946$ ;

Unit: A

Display:

I	0.946
---	-------

#### 6.5.2 Write data

##### Example3: Single phase switching output remote control (control character: 0012H)

Read in data frames	01 10 00 12 00 01 02 00 02 24 e3 (DO1 closing)
	01 10 00 12 00 01 02 00 01 64 e2 (DO2 closing)
	01 10 00 12 00 01 02 00 03 e5 23 (DO1, DO2 closing)
Return Data frame	01 10 00 12 00 01 A1 CC (If no data returning indicate setting is unsuccessful)

Description:

To switching output status bit, remote write in 1, then closing; read in 0, then opening.

When relay closing duration is Nonzero, indicate: relay adopt pulse mode, relay closing duration as setting value; if duration setting as 0, then indicate: relay adopt holding mode.

##### Example 2: Three phase switching output remote control (control word: 002aH)

Setting Data frame	01 10 00 2a 00 01 02 00 02 20 5b (DO1 closing)
	01 10 00 2a 00 01 02 00 01 60 5a (DO2 closing)
	01 10 00 2a 00 01 02 00 01 60 5a (DO1, DO2 closing)
Return Data frame	01 10 00 2a 00 01 20 01 (If no data returning indicate setting is unsuccessful)

## 7 Common fault analysis

Table 9 Common Fault Analysis

Fault content	Analysis	Remarks
No display after power on	Check Aux power voltage is within the range	
Voltage or current is incorrect	Check the voltage/current ratio Check voltage transformer/current transformer is intact	
Communication failure	Check whether the address,baud rate,check digit,etc. in the communication settings are consistent with the host computer. Check RS485 converter is working Add resistance at the end of communication Check wiring is correct	